

User's guide

SMA1 + MTA1

Absolute linear encoder

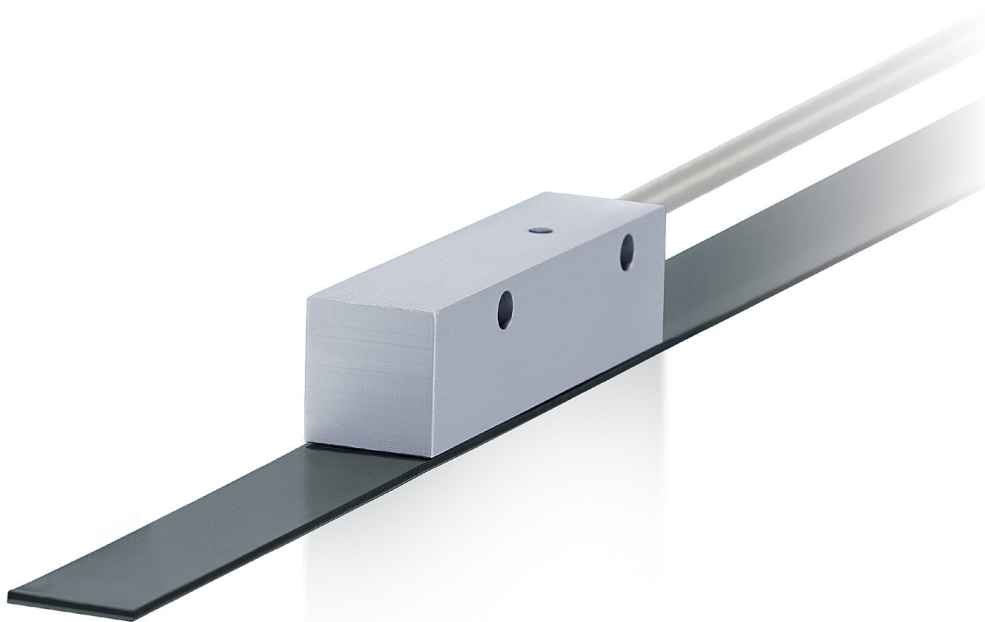

lika

Smart encoders & actuators

This publication was produced by Lika Electronic s.r.l. 2016. All rights reserved. Tutti i diritti riservati. Alle Rechte vorbehalten. Todos los derechos reservados. Tous droits réservés.

This document and information contained herein are the property of Lika Electronic s.r.l. and shall not be reproduced in whole or in part without prior written approval of Lika Electronic s.r.l. Translation, reproduction and total or partial modification (photostat copies, film and microfilm included and any other means) are forbidden without written authorisation of Lika Electronic s.r.l.

The information herein is subject to change without notice and should not be construed as a commitment by Lika Electronic s.r.l. Lika Electronic s.r.l. reserves the right to make all modifications at any moments and without forewarning.

This manual is periodically reviewed and revised. As required we suggest checking if a new or updated edition of this document is available at Lika Electronic s.r.l.'s website. Lika Electronic s.r.l. assumes no responsibility for any errors or omissions in this document. Critical evaluation of this manual by the user is welcomed. Your comments assist us in preparation of future documentation, in order to make it as clear and complete as possible. Please send an e-mail to the following address info@lika.it for submitting your comments, suggestions and criticisms.

The logo for Lika Electronic s.r.l. consists of the word "lika" in a bold, lowercase, sans-serif font. The letter "i" has a dot, and the letter "a" has a tail that curves slightly to the right.

General contents

User's guide.....	1
General contents.....	3
Subject index.....	6
Typographic and iconographic conventions.....	7
Preliminary information.....	8
1 - Safety summary.....	9
1.1 Safety.....	9
1.2 Electrical safety.....	9
1.3 Mechanical safety.....	10
2 - Identification.....	10
3 - Mounting instructions.....	11
3.1 Overall dimensions.....	11
3.2 Magnetic scale.....	11
3.3 Mounting the sensor.....	12
4 - Electrical connections.....	14
4.1 T12 cable specifications.....	14
4.2 M12 12-pin connector.....	15
4.3 Ground connection.....	15
4.4 1Vpp sinusoidal output signals.....	15
4.5 Diagnostic LED.....	15
4.6 Features summary.....	15
5 - SSI interface.....	16
5.1 SSI (Synchronous Serial Interface).....	16
5.2 LSB right aligned protocol.....	17
5.3 Recommended transmission rates.....	18
5.4 Helpful information.....	18
5.5 Recommended SSI circuit.....	19
6 - BiSS B-mode interface.....	20
6.1 XML file.....	20
6.2 Communication.....	20
6.3 Register Mode.....	20
Register address.....	20
DATA.....	21
CRC.....	21
6.4 Sensor mode.....	21
Position.....	22
Error.....	22
Warning.....	22
CRC.....	22
6.5 Used registers.....	23
Profile ID.....	23
Serial number.....	24
Command.....	24
Normal operation.....	24
Save parameters on EEPROM.....	24
Save and activate Preset / Offset.....	24
Load and save default parameters.....	24

Configuration	25
Select BiSS / SSI.....	25
Set preset / offset.....	25
Enable preset / offset.....	25
Output code.....	26
Counting direction.....	26
Absolute resolution	26
Preset / Offset	27
Device type	28
SINE / COSINE resolution	28
Device ID	28
Manufacturer ID	29
6.6 Application note.....	29
6.7 Examples.....	29
6.7.1 Setting the Configuration register.....	29
6.7.2 Setting the Preset / Offset register.....	30
6.8 Recommended BiSS circuit.....	30
7 - BiSS C-mode interface	31
7.1 XML file.....	31
7.2 Communication.....	31
7.3 Single Cycle Data.....	32
Position.....	32
Error.....	32
Warning.....	32
CRC.....	33
7.4 Control Data CD.....	33
Register address.....	33
RW.....	33
DATA.....	33
CRC.....	34
7.5 Used registers.....	34
Profile ID	35
Serial number	35
Command	35
Normal operation.....	35
Save parameters on EEPROM.....	35
Save and activate Preset / Offset.....	35
Load and save default parameters.....	35
Configuration	36
Set preset / offset.....	36
Enable preset / offset.....	36
Output code.....	37
Counting direction.....	37
Absolute resolution	37
Preset / Offset	38
Device type	39
SINE / COSINE resolution	39
Device ID	39
Manufacturer ID	40
7.6 Application note.....	40

7.7 Examples.....	40
7.7.1 Setting the Configuration register.....	40
7.7.2 Setting the Preset / Offset register.....	41
7.8 Recommended BiSS circuit.....	41
8 - 1Vpp sine/cosine output signals.....	42
8.1 Output signals voltage level.....	42
9 - Error and fault diagnostics.....	43
9.1 Diagnostic LED.....	43
10 - Maintenance.....	44
11 - Troubleshooting.....	45
12 - Default parameters list.....	46

Subject index

A

Absolute resolution.....26, 37

C

Command.....24, 35

Configuration.....25, 36

Counting direction.....26, 37

D

Device ID.....28, 39

Device type.....28, 39

E

Enable preset / offset.....25, 36

L

Load and save default parameters.....24, 35

M

Manufacturer ID.....29, 40

N

Normal operation.....24, 35

O

Offset.....27, 38

Output code.....26, 37

P

Preset.....27, 38

Preset / Offset.....27, 38

Profile ID.....23, 35

S

Save and activate Preset / Offset.....24, 35

Save parameters on EEPROM.....24, 35

Select BiSS / SSI.....25

Serial number.....24, 35

Set preset / offset.....25, 36



SINE / COSINE resolution.....28, 39

Typographic and iconographic conventions

In this guide, to make it easier to understand and read the text the following typographic and iconographic conventions are used:

- parameters and objects both of the device and the interface are coloured in **GREEN**;
- alarms are coloured in **RED**;
- states are coloured in **FUCSIA**.

When scrolling through the text some icons can be found on the side of the page: they are expressly designed to highlight the parts of the text which are of great interest and significance for the user. Sometimes they are used to warn against dangers or potential sources of danger arising from the use of the device. You are advised to follow strictly the instructions given in this guide in order to guarantee the safety of the user and ensure the performance of the device. In this guide the following symbols are used:

	This icon, followed by the word WARNING , is meant to highlight the parts of the text where information of great significance for the user can be found: user must pay the greatest attention to them! Instructions must be followed strictly in order to guarantee the safety of the user and a correct use of the device. Failure to heed a warning or comply with instructions could lead to personal injury and/or damage to the unit or other equipment.
	This icon, followed by the word NOTE , is meant to highlight the parts of the text where important notes needful for a correct and reliable use of the device can be found. User must pay attention to them! Failure to comply with instructions could cause the equipment to be set wrongly: hence a faulty and improper working of the device could be the consequence.
	This icon is meant to highlight the parts of the text where suggestions useful for making it easier to set the device and optimize performance and reliability can be found. Sometimes this symbol is followed by the word EXAMPLE when instructions for setting parameters are accompanied by examples to clarify the explanation.

Preliminary information

This guide is designed to provide the most complete and exhaustive information the operator needs to correctly and safely install and operate the **SMA1 series absolute linear encoder**. SMA1 is designed to measure displacements in industrial machines and automation systems. The measurement system includes a magnetic tape and a magnetic sensor with conversion electronics. The scale is magnetized with a coded sequence of North-South poles generating an absolute pattern. As the encoder moves along the magnetic scale, the sensor detects the displacement and yields the absolute position information through the SSI interface (order code SMA1-GA2-...) or the BiSS B-mode interface (order code SMA1-SBx-...) or the BiSS C-mode interface (order code SMA1-SCx-...). The BiSS interface versions further provide additional 1Vpp sine-cosine signals for speed feedback. It is mandatory to pair the sensor with the **MTA1 type magnetic tape**.

To make it easier to read and understand the text, this guide can be divided into five main sections.

In the first section some general information concerning the safety, the mechanical installation and the electrical connection as well as tips for setting up and running properly and efficiently the unit are provided.

In the second section, entitled **SSI interface**, both general and specific information is given on the SSI interface.

In the third section, entitled **BiSS B-mode interface**, both general and specific information is given on the BiSS B-mode interface. In this section the parameters implemented in the unit are fully described.

In the fourth section, entitled **BiSS C-mode interface**, both general and specific information is given on the BiSS C-mode interface. In this section the parameters implemented in the unit are fully described.

Finally, in the fifth section, entitled **1Vpp sine-cosine output signals**, some information is given on the additional sinusoidal signals.

1 - Safety summary

1.1 Safety

- Always adhere to the professional safety and accident prevention regulations applicable to your country during device installation and operation;
- installation and maintenance operations have to be carried out by qualified personnel only, with power supply disconnected and stationary mechanical parts;
- device must be used only for the purpose appropriate to its design: use for purposes other than those for which it has been designed could result in serious personal and/or the environment damage;
- high current, voltage and moving mechanical parts can cause serious or fatal injury;
- warning ! Do not use in explosive or flammable areas;
- failure to comply with these precautions or with specific warnings elsewhere in this manual violates safety standards of design, manufacture, and intended use of the equipment;
- Lika Electronic assumes no liability for the customer's failure to comply with these requirements.

1.2 Electrical safety

- Turn OFF the power supply before connecting the device;
- connect the unit according to the explanation in the "4 - Electrical connections" section;
- the wires of unused signals must be cut at different lengths and insulated singularly;
- in compliance with 2004/108/EC norm on electromagnetic compatibility, following precautions must be taken:
 - before handling and installing the equipment, discharge electrical charge from your body and tools which may come in touch with the device;
 - power supply must be stabilized without noise; install EMC filters on device power supply if needed;
 - always use shielded cables (twisted pair cables whenever possible);
 - avoid cables runs longer than necessary;
 - avoid running the signal cable near high voltage power cables;
 - mount the device as far as possible from any capacitive or inductive noise source; shield the device from noise source if needed;
 - to guarantee a correct working of the device, avoid using strong magnets on or near by the unit;
 - minimize noise by connecting the cable shield and/or the sensor to ground. Make sure that ground is not affected by noise. The connection point to ground can be situated both on the device side and on user's side. The best solution to minimize the interference must be carried out by the user.



1.3 Mechanical safety

- Install the device following strictly the information in the "3 - Mounting instructions" section;
- mechanical installation has to be carried out with stationary mechanical parts;
- do not disassemble the unit;
- do not tool the unit;
- delicate electronic equipment: handle with care; do not subject the device to knocks or shocks;
- protect the unit against acid solutions or chemicals that may damage it;
- respect the environmental characteristics of the product;
- we suggest installing the unit providing protection means against waste, especially swarf as turnings, chips, or filings; should this not be possible, please make sure that adequate cleaning measures (as for instance brushes, scrapers, jets of compressed air, etc.) are in place in order to prevent the sensor and the magnetic scale from jamming.

2 - Identification

Device can be identified through the **order code** and the **serial number** printed on the label applied to its body. Information is listed in the delivery document too. Please always quote the order code and the serial number when reaching Lika Electronic for purchasing spare parts or needing assistance. For any information on the technical characteristics of the product refer to the technical datasheet.



Warning: devices having order code ending with "/Sxxx" may have mechanical and electrical characteristics different from standard and be supplied with additional documentation for special connections (Technical Info).

3 - Mounting instructions



WARNING

Installation has to be carried out by qualified personnel only, with power supply disconnected and mechanical parts compulsorily in stop.

3.1 Overall dimensions

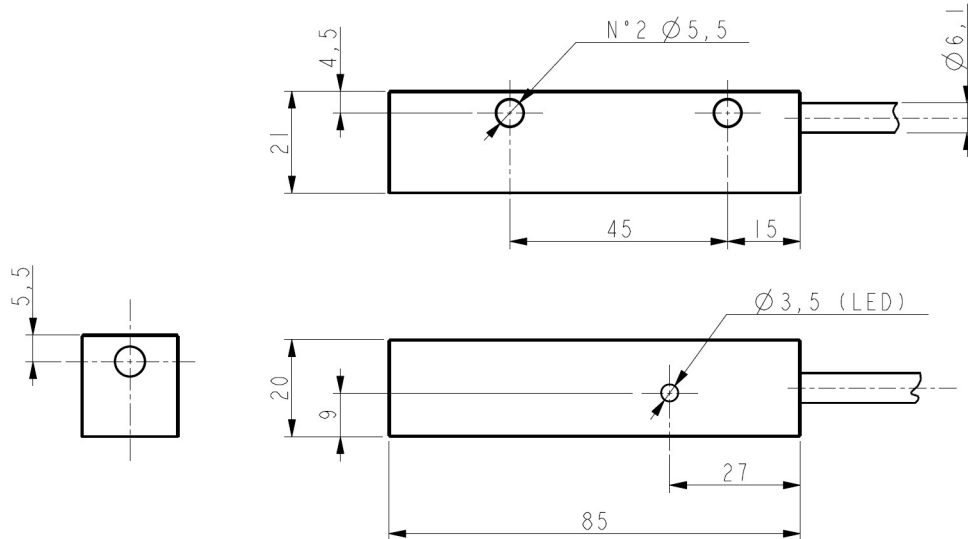

3.2 Magnetic scale

The sensor has to be paired with the **MTA1 type magnetic scale** only. For detailed information on the MTA1 type scale and how to mount it refer to the specific technical documentation.

Install the unit providing protection means against waste, especially swarf as turnings, chips, or filings; should this not be possible, please make sure that adequate cleaning measures (as for instance brushes, scrapers, jets of compressed air, etc.) are in place in order to prevent the sensor and the magnetic scale from jamming.

Make sure the mechanical installation meets the system's requirements of distance, planarity and parallelism between the sensor and the scale indicated in Figure 2 all along the whole measuring length.

The Figure 1 below shows how the sensor and the scale must be installed; the arrow indicates the **standard counting direction** (increasing count, see the parameter **Counting direction** on page 26 / 37).



WARNING

The system cannot work if mounted otherwise than illustrated in the Figures.

3.3 Mounting the sensor

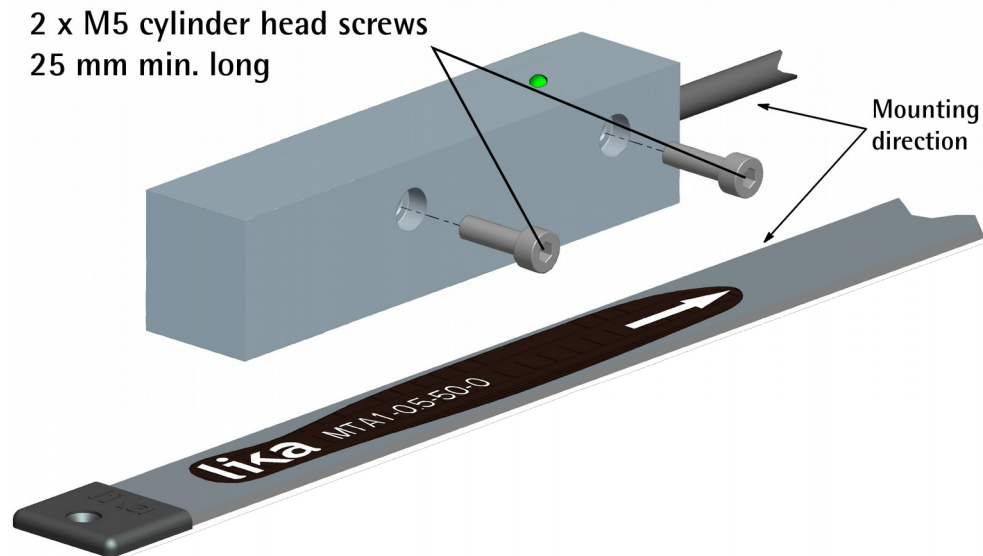

Figure 1

Make sure the mechanical installation complies with the system requirements concerning distance, planarity and parallelism between the sensor and the scale. Avoid contact between the parts. Sensor is fixed by means of **two M5 25 mm min. long cylinder head screws** inserted in the provided holes. Recommended **minimum bend radius** of the cable: $R \geq 45 \text{ mm}$.

The allowed gap between the sensor and the scale is 0.1 mm ÷ 0.3 mm (0.004" ÷ 0.012").

Do not use the cover strip, it would cause an excessive gap between the sensor and the scale surface.



WARNING

Make sure the mechanical installation complies with the system requirements concerning distance, planarity and parallelism between the sensor and the scale as shown in Figure 2 all along the whole measuring length.

Mount the sensor as shown in the Figures. Please mind the direction of the cable outlet. The system cannot operate if mounted otherwise than illustrated in the Figures.

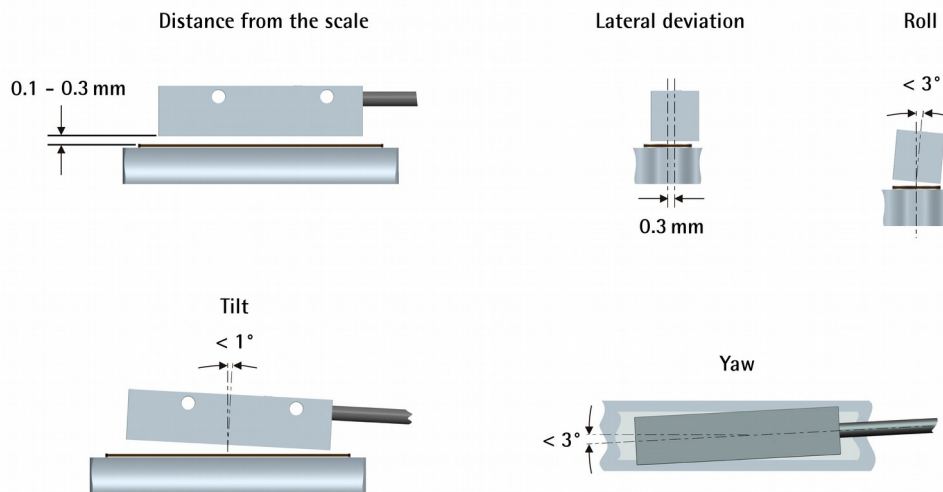
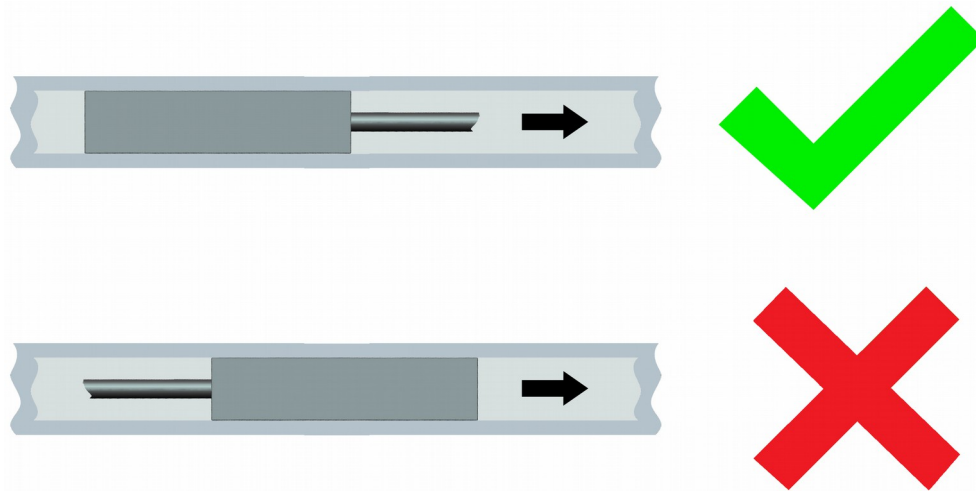

Figure 2



WARNING

After having installed the sensor on the magnetic scale a zero setting operation is compulsorily required. The zero setting operation is further required every time either the sensor or the scale is replaced. Refer to pages 27 and 38. Not available for SSI interface.

4 - Electrical connections



WARNING

Electrical connection has to be carried out by qualified personnel only, with power supply disconnected and mechanical parts compulsorily in stop.



WARNING

If wires of unused signals come in contact, irreparable damage could be caused to the device. Please insulate them singularly.

Connections

Function	T12 cable	M12 12-pin
0Vdc	White / Green	1
+Vdc ¹	Brown / Green	2
Clock IN + / MA +	Violet	3
Clock IN - / MA -	Yellow	4
Data OUT + / SLO +	Grey	5
Data OUT - / SLO -	Pink	6
not connected	White	7
not connected	Blue	8
A (cos+) ²	Green	9
/A (cos-) ²	Brown	10
B (sin+) ²	Red	11
/B (sin-) ²	Black	12

- 1 See the order code for the power supply voltage level.



EXAMPLE

SMA1-SC2-... → +Vdc = +10Vdc +30Vdc

SMA1-SB1-... → +Vdc = +5Vdc ±5%

- 2 Additional sinusoidal signals are only available in the BiSS interface. For any further information please refer to the "8 - 1Vpp sine/cosine output signals" section on page 42.

4.1 T12 cable specifications

Model : LIKA T12 cable

Wires : 4 x 0.25 mm² + 4 x 2 x 0.14 mm² twisted pairs

Shield : tinned copper braid

External diameter : Ø 6.1 mm ± 0.10 mm

Conductor resistance : <90 Ω/km (0.25 mm²); <148 Ω/km (0.14 mm²)

Minimum bending radius : Ø x 7.5

4.2 M12 12-pin connector

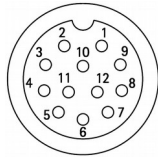

M12 12-pin connector
A coding
Male frontal side

4.3 Ground connection

Minimize noise by connecting the shield and/or the sensor to ground. Make sure that ground is not affected by noise. The connection point to ground can be situated both on the device side and on user's side. The best solution to minimize the interference must be carried out by the user.

4.4 1Vpp sinusoidal output signals

For any further information on the 1Vpp sinusoidal signals please refer to the "8 - 1Vpp sine/cosine output signals" section on page 42. Additional sinusoidal signals are only available in the BiSS interface.

4.5 Diagnostic LED

For any further information on the diagnostic LED please refer to the "9 - Error and fault diagnostics" section on page 43.

4.6 Features summary

	SMA1-xxx-5-...
Absolute track physical resolution	5 μ m
Sine/cosine track resolution ¹	1 mm
Max. scale length (max. measuring length)	5,100 mm (5,015 mm)
Pole pitch dimension	1 mm
Max. information (max. value)	20 bits (1,048,575)

¹ Sine/cosine signals only available in the BiSS interface.

5 - SSI interface

Order code: SMA1-GA2-5-...

5.1 SSI (Synchronous Serial Interface)



SSI (the acronym for **Synchronous Serial Interface**) is a synchronous point-to-point serial interface engineered for unidirectional data transmission between one Master and one Slave. Developed in the first eighties, it is based on the RS-

422 serial standard. Its most peculiar feature is that data transmission is achieved by synchronizing both the Master and the Slave devices to a common clock signal generated by the controller; in this way the output information is clocked out at each controller's request. Furthermore only two pairs of twisted wires are used for data and clock signals, thus a six-wire cable is required.

The main advantages in comparison with parallel or asynchronous data transmissions are:

- less conductors are required for transmission;
- less electronic components;
- possibility of insulating the circuits galvanically by means of optocouplers;
- high data transmission frequency;
- hardware interface independent from the resolution of the absolute encoder.

Furthermore the differential transmission increases the noise immunity and decreases the noise emissions. It allows multiplexing from several encoders, thus process controls are more reliable with simplified line design and easier data management.

Data transmission is carried out as follows.

At the first falling edge of the clock signal (**1**, the logic level changes from high to low) the absolute position value is stored while at the following rising edge (**2**) the transmission of data information begins starting from the MSB.

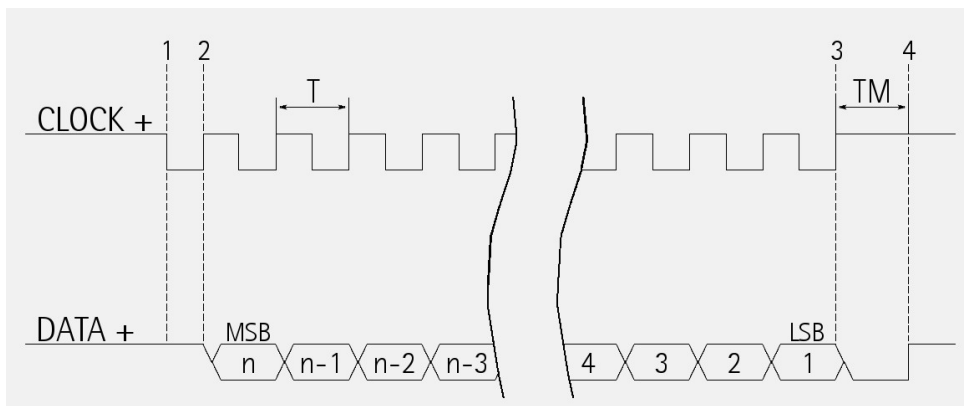

At each change of the clock signal and at each subsequent rising edge (**2**) one bit is clocked out at a time, up to LSB, so completing the data word transmission. The cycle ends at the last rising edge of the clock signal (**3**). This

means that up to $n + 1$ rising edges of the clock signals are required for each data word transmission (where n is the bit resolution); for instance, a 13-bit encoder needs 14 clock edges. If the number of clocks is greater than the number of bits of the data word, then the system will send a zero (low logic level signal) at each additional clock, zeros will either lead (LSB ALIGNED protocol) or follow (MSB ALIGNED protocol) or lead and/or follow (TREE FORMAT protocol) the data word. After the period T_m monoflop time, having a typical duration of 12 μ sec, calculated from the end of the clock signal transmission, the encoder is then ready for the next transmission and therefore the data signal is switched high.

The clock signal has a typical logic level of 5V, the same as the output signal which has customarily a logic level of 5V in compliance with RS-422 standard.

The output code can be either Binary or Gray (see the order code).

5.2 LSB right aligned protocol

"LSB right aligned" protocol allows to right align the bits, beginning from MSB (most significant bit) to LSB (least significant bit); LSB is then sent at the last clock cycle. If the number of clock signals is higher than the data bits, then unused bits are forced to logic level low (0) and lead the data word. This protocol can be used in sensors having any resolution. The word has a length of 25 bits.

The device uses 20 bits to provide the position information, unused bits (from 21 to 25) are set to 0 (zero).

Thus:

Model	Resolution	Length of the word	Max. number of information
SMA1-GA2-5-...	0.005 mm	25 bits	20 bits (1,048,575)

The output code of the sensor can be GRAY or BINARY (see the order code).

The length of each information is equal to the resolution (5 μ m).

Position structure:

bit	25 ... 21	20	...	1
value	00000	MSB	...	LSB



WARNING

The position value issued by the sensor is expressed in pulses; to convert the pulses into a metric measuring unit you must multiply the number of detected pulses by the resolution.



EXAMPLE

SMA1-GA2-5-...

resolution = 5 μ m

detected pulses = 123

position value = $123 * 5 = 615 \mu\text{m} = 0.615 \text{ mm}$

5.3 Recommended transmission rates

The SSI interface has a frequency of data transmission ranging between 100 kHz and 1 MHz.

The CLOCK signal and DATA signal comply with the "EIA standard RS-422".

The clock frequency (baud rate) depends on the length of the cable and must comply with the technical information reported in the following table:

Cable length	Baud rate
< 50 m	< 400 kHz
< 100 m	< 300 kHz
< 200 m	< 200 kHz
< 400 m	< 100 kHz

The time interval between two Clock sequence transmissions must be at least 16 μs ($T_p > 16 \mu\text{s}$).

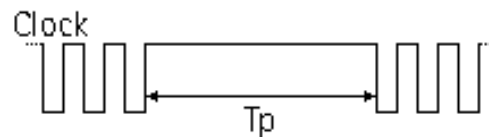

5.4 Helpful information

- The position information increases when the sensor moves in the direction indicated by the arrow in the Figure 1, starting from a min. value up to a max. value; min. and max. values depend on the specific MTA1 magnetic scale installed in your application.

5.5 Recommended SSI circuit

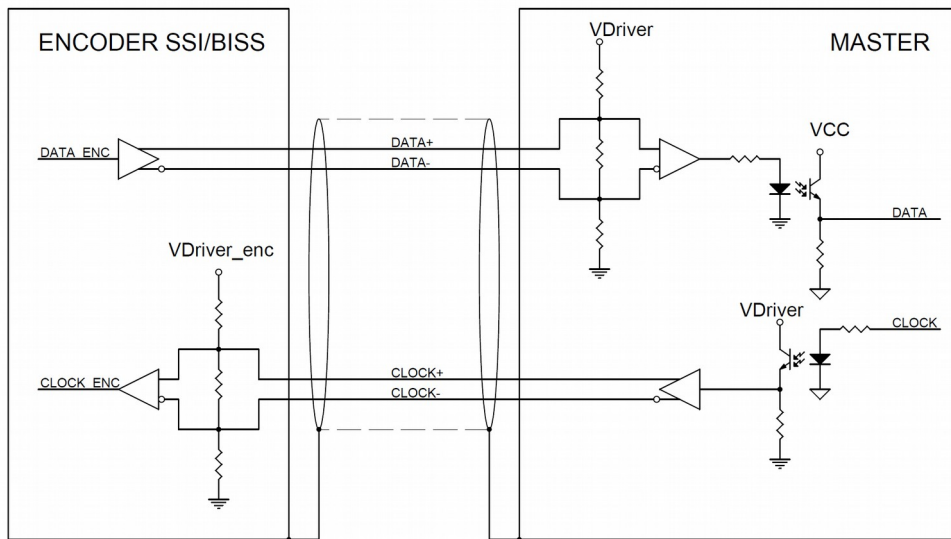

6 - BiSS B-mode interface

Order code: SMA1-SBx-...

SMA1 is a Slave device and complies with the "BiSS B-mode interface" and the "Standard encoder profile".

For detailed information not listed in this manual please refer to the official BiSS website (www.biss-interface.com).

The sensor is designed to operate in a point-to-point configuration and has to be installed in a "single Master, single Slave" network.



WARNING

Never connect the sensor in a "single Master - Multi Slave" network.

CLOCK MA and DATA SLO signal levels comply with the "EIA standard RS-422".

6.1 XML file

The product is supplied with an XML file **idbiss4C69.xml** (see at www.lika.biz > **LINEAR ENCODERS** > **ABSOLUTE MAGNETIC SENSORS** > **SMA1**). Install the XML file in your BiSS Master device.

6.2 Communication

The BiSS B-mode protocol uses two types of data transmission protocols:

- **Register Mode:** this is used to read data from or write data to the registers of the Slave. See the section "6.3 Register Mode" on page 20.
- **Sensor mode:** this is used to transfer process data from the Slave device to the Master device. See the section "6.4 Sensor mode" on page 21.

6.3 Register Mode

Main data fields available in the register mode are described under this section. For the complete structure and information please refer to the official documents supplied by BiSS organization.

Register address

(7 bits)

This is the address of the register; it specifies the register you need to read from or write to.

DATA

(8 bits)

When writing to the register: this is the value to be set in the register (i.e. transmitted from the Master to the Slave).

When reading from the register: this is the value read in the register (i.e. transmitted from the Slave to the Master).

Data bit structure:

bit	7	0
	MSB	LSB

CRC

(4 bits)

CRC, namely Cyclic Redundancy Check, is the error checking field resulting from a "Redundancy Check" calculation performed on the message contents. This is intended to check whether transmission has been performed properly (inverted output).

Polynomial: X^4+X^1+1 (binary: 10011)

Logic circuit:

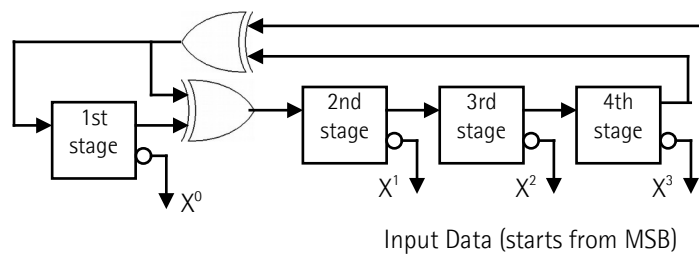

6.4 Sensor mode

Sensor mode data (32 bits) consists of the following values: 24-bit position value (**Position**), 1 error bit (**Error**, nE), 1 warning bit (**Warning**, nW) and CRC checking (**CRC**, 6 bits).

Sensor data structure:

Start	DATA				Stop
	31 ... 8	7	6	5 ... 0	
	Position	Error	Warning	CRC	



WARNING

Multi-cycle-data bit (MCD) is not utilized, thus the Master must not require it!

Position

(24 bits)

Process data to be transmitted from the Slave to the Master.

The transmission starts with the MSB (most significant bit) and ends with the LSB (least significant bit).

bit	31 ... 28	27	...	8
value	0000	MSB	...	LSB

To convert the position value into mm, multiply the received data value by the resolution (see 4Dhex **Absolute resolution** register).

**EXAMPLE 1**

SMA1-SB2-5-..., **Absolute resolution** = 32 hex, 0.05 mm

detected pulses = 123

position = 123 * 0.05 = 6.15 mm

**EXAMPLE 2**

SMA1-SB2-5-..., **Absolute resolution** = 64 hex, 0.1 mm

detected pulses = 1569

position = 1569 * 0.1 = 156.9 mm

Error

(1 bit)

It is intended to communicate a normal or fault status of the Slave.

nE = "1": normal status (no active error)

= "0": error status: the scale is not sensed properly.

Check the gap between the sensor and the scale, check both planarity and parallelism. See the "3 - Mounting instructions" section on page 11.

Warning

(1 bit)

Not used (nW = "1")

CRC

(6 bits)

CRC, namely Cyclic Redundancy Check, is the error checking field resulting from a "Redundancy Check" calculation performed on the message contents. This is intended to check whether transmission has been performed properly (inverted output).

Polynomial: X^6+X^1+1 (binary: 1000011)

Logic circuit:

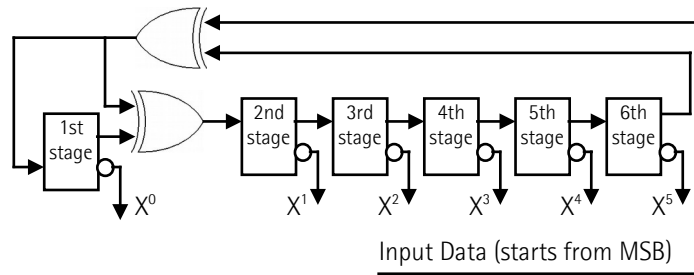

6.5 Used registers

Register (hex)	Function
42 - 43	Profile ID
44 ... 47	Serial number
48	Command
49	Configuration
4D	Absolute resolution
51 ... 53	Preset / Offset
55	Device type
58	SINE / COSINE resolution
78 ... 7D	Device ID
7E - 7F	Manufacturer ID

All registers in this section are listed according to the following scheme:

Function name

[Address, access]

Description of the function and default value.

- Address: register address is expressed in hexadecimal notation.
- Access:
 - ro = read only
 - rw = read and write
 - wo = write only
- Default parameter values are written in **bold**.

Profile ID

[42 - 43, ro]

These registers contain the identification code of the used profile.

Register	42	43
Hex	28	14

See "Standard encoder profile", "data format", "Variant 0-24".

Serial number**[44 ... 47, ro]**

These registers show the serial number of the device expressed in hexadecimal notation.

Register 44 : year of production

Register 45 : week of production

Registers 46 and 47 : serial number in ascending order

Command**[48, wo]**

Value	Function
00	Normal operation
01	Save parameters on EEPROM
02	Save and activate Preset / Offset
04	Load and save default parameters

After having set a new value in some register, use the **Save parameters on EEPROM** function in this register to store it. Set "01" in the register.

After having set a Preset / Offset value, use the **Save and activate Preset / Offset** function in this register to both store and activate the preset / offset at the same time. Set "02" in the register.

Load and save default parameters: default parameters are set at the factory by Lika Electronic engineers to allow the operator to run the device for standard operation in a safe mode. As soon as the command is sent the default parameters are uploaded and activated. All parameters which have been set previously are overwritten, thus previously set values are lost. The complete list of machine data and the relevant default parameters preset by Lika Electronic engineers are available on page 46. Set "04" in the register.

**WARNING**

As soon as the **Load and save default parameters** command is sent, all parameters which have been set previously are overwritten, thus previously set values are lost!

As soon as the command is sent, the register is set back to "00" (**Normal operation**) automatically.

Wait min. 30 ms (EEPROM writing time) before using a new function.

Default = 00 (**Normal operation**)

Configuration

[49, rw]

Bit	Function	Bit = 0	Bit = 1
0	Select BiSS / SSI	BiSS	SSI
1	Set preset / offset	Preset	Offset
2	Enable preset / offset	Enable	Disable
3	Not used		
4	Not used		
5	Output code	Gray	Binary
6	Counting direction *	Standard	Inverted
7	Not used		

*: it affects the absolute position information, not the sine/cosine signals

Select BiSS / SSI

It sets whether the output data is transmitted using the BiSS B-mode protocol (0) or the SSI protocol (1).

Default = 0 (BiSS B-mode)

Set preset / offset

This parameter is available only if the parameter **Enable preset / offset** is set to ENABLE. It allows to activate either the preset function (**Set preset / offset** = PRESET) or the offset function (**Set preset / offset** = OFFSET); the Preset or Offset value has to be set in the **Preset / Offset** register. After having enabled the preset / offset functions (**Enable preset / offset** = ENABLE), this item allows to activate either the preset function or the offset function. The value set in the **Preset / Offset** register will have a different meaning depending on the value of this parameter whether it is set to PRESET (0) or OFFSET (1). In the first case (**Set preset / offset** = PRESET) the **Preset / Offset** register is used to set the preset value; while in the second case (**Set preset / offset** = OFFSET) the **Preset / Offset** register is used to set the offset value. To activate the preset / offset value use the **Save and activate Preset / Offset** function in the **Command** register (set "02" in the register 48).

For any information on the preset and the offset functions refer to the **Preset / Offset** register on page 27.

Default = 0 (Preset)

Enable preset / offset

It enables / disables the preset / offset functions. After having enabled the use of the functions you have to choose whether to activate the preset or the offset in the **Set preset / offset** parameter. Then to active a new value, set it next to the **Preset / Offset** register and send the **Save and activate Preset / Offset** command (set "02" in the register 48).

Default = 0 (enable)

Output code

The sensor provides the absolute position information in the desired code format: GRAY (0) or BINARY (1).

Default = 1 (Binary)

Counting direction

The **standard counting direction** is to be intended with sensor moving as indicated by the arrow in Figure 1. This parameter allows to reverse the counting direction. In other words it allows the count up when the sensor moves in reverse of the standard direction, i.e. in the opposite direction to the one shown by the arrow in Figure 1. It is possible to choose the following options: STANDARD (0) and INVERTED (1). When the counting direction is set to STANDARD -**Counting direction** = STANDARD-, the position information increases when the sensor moves according to the arrow in Figure 1. When the option INVERTED is set -**Counting direction** = INVERTED-, the position information increases when the sensor moves in reverse of the standard direction, i.e. in the opposite direction to the one shown by the arrow in Figure 1.

Default = 0 (Standard)



NOTE

The **Counting direction** parameter affects the absolute position information, not the sine/cosine signals.

The new setting will be active immediately after transmission. Use the **Save parameters on EEPROM** function (set "01" in the register 48) to store the new value.

Configuration register default value = 20h

Absolute resolution

[4D, rw]

It allows to read and set the resolution of the absolute sensor.

64hex : Resolution = 0.1 mm (max position = 00 FF FFh, 16 bits)

32hex : Resolution = 0.05 mm (max position = 01 FF FFh, 17 bits)

0Ahex : Resolution = 0.01 mm (max position = 07 FF FFh, 19 bits)

05hex : Resolution = 0.005 mm (max position = 0F FF FFh, 20 bits)

The new setting will be active immediately after transmission. Use the **Save parameters on EEPROM** function (set "01" in the register 48) to store the new value.



NOTE

If the preset / offset functions are active, after having set a new value next to this **Absolute resolution** register, then you must check the value in the

Preset / Offset register and activate it by sending the command **Save and activate Preset / Offset** (set "02" in the register 48).

Default = 05h.

Preset / Offset

[51 ... 53, rw]

This function is available only if the **Enable preset / offset** parameter in the **Configuration** register is set to ENABLE. Furthermore it has a double function depending on whether the **Set preset / offset** parameter in the **Configuration** register is set to PRESET or OFFSET. In the first case (**Set preset / offset** = PRESET) the **Preset / Offset** register is used to set the preset value; while in the second case (**Set preset / offset** = OFFSET) the **Preset / Offset** register is used to set the offset value.



WARNING

Activate the preset / offset value only when the device is not moving.

Preset

The preset function is meant to assign a value to a desired physical position of the sensor. The chosen physical position will get the value set next to this item and all the previous and following positions will get a value according to it. This function is useful, for example, when the zero position of the sensor and the zero position of the axis need to match. The preset value will be set for the position of the sensor in the moment when the preset value is activated. To activate the preset, stop the sensor in the desired position, enter the desired value next to this **Preset / Offset** register and then send the **Save and activate Preset / Offset** command in the **Command** register (set "02" in the register 48).

Offset

The offset function is meant to assign a value to a desired physical position of the sensor so that the output position information is shifted according to the value set next to this **Preset / Offset** register. The number of transmitted values will match the maximum number of position information as per the set resolution, but the output information will range between the **Preset / Offset** value (minimum value) and the sum of the max. position information as per the set resolution (see the **Absolute resolution** register) + the **Preset / Offset** value (maximum value). The offset value will be set for the position of the sensor in the moment when the offset value is activated. To activate the offset, stop the sensor in the desired position, enter the desired value next to this **Preset / Offset** register and then send the **Save and activate Preset / Offset** command in the **Command** register (set "02" in the register 48).

Preset / Offset structure:

Reg.	51	52	53
	MSB	...	LSB
	$2^{23} - 2^{16}$	$2^{15} - 2^8$	$2^7 - 2^0$

Use the **Save and activate Preset / Offset** function (set "02" in the register 48) to store and activate the new value.

The max. allowed Preset value depends on the set resolution:

resolution = 0.1 → max preset = 00 FF FFh (16 bits)

resolution = 0.05 → max preset = 01 FF FFh (17 bits)

resolution = 0.01 → max preset = 07 FF FFh (19 bits)

resolution = 0.005 → max preset = 0F FF FFh (20 bits)

The Offset value must be less than or equal to the difference between the overall position information (24 bits, see **Position**) and the max. position information allowed by the set resolution (see the **Absolute resolution** register).

Default = **00h**.

Device type

[55, ro]

This register describes the type of device.

Default = **06h**: linear encoder BiSS + SINE/COSINE signals

SINE / COSINE resolution

[58, ro]

This register describes the period of the sine/cosine signals.

Default = **01h**: resolution = 1 mm

Device ID

[78 ... 7D, ro]

These registers show the Device ID, hexadecimal values are according to ASCII code.

Reg.	78	79	7A	7B	7C	7D
Hex	53	4D	41	31	xx	xx
ASCII	S	M	A	1	-	-

xx: software version

Manufacturer ID

[7E - 7F, ro]

These registers show the Manufacturer ID, hexadecimal values are according to ASCII code.

Reg.	7E	7F
Hex	4C	69
ASCII	L	i

Li = Lika Electronic.

6.6 Application note

Device communication specifications:

Parameter	Min	Max
Clock Frequency Sensor Mode	350 kHz	10 MHz
Clock Frequency Register Mode	80 kHz	250 kHz
Timeout Sensor Mode	1.5 μ s	3.5 μ s
Timeout Register mode	15.5 μ s	17.5 μ s

6.7 Examples

All values are expressed in hexadecimal notation, unless otherwise indicated.



6.7.1 Setting the Configuration register

Bit 0 Select BiSS / SSI	= BiSS	= 0
Bit 1 Set preset / offset	= PRESET	= 0
Bit 2 Enable preset / offset	= ENABLE	= 0
Bit 3	= not used	= 0
Bit 4	= not used	= 0
Bit 5 Output code	= BINARY	= 1
Bit 8 Counting direction	= INVERTED	= 1
Bit 7	= not used	= 0

01100000₂ = 60 hex

Function	ADR	DATA Tx
writing the Configuration register	49	60
Save parameters on EEPROM	48	01



6.7.2 Setting the Preset / Offset register

After having enabled and chosen the PRESET function (**Enable preset / offset** = ENABLE; **Set preset / offset** = PRESET in the **Configuration** register, see the previous "6.7.1 Setting the Configuration register" section), you want to set and activate the new Preset value = $100000_{10} = 01\ 86\ A0h$

Function	ADR	DATA Tx
writing the Preset / Offset register	51	01
	52	86
	53	A0
Save and activate Preset / Offset	48	02

6.8 Recommended BiSS circuit

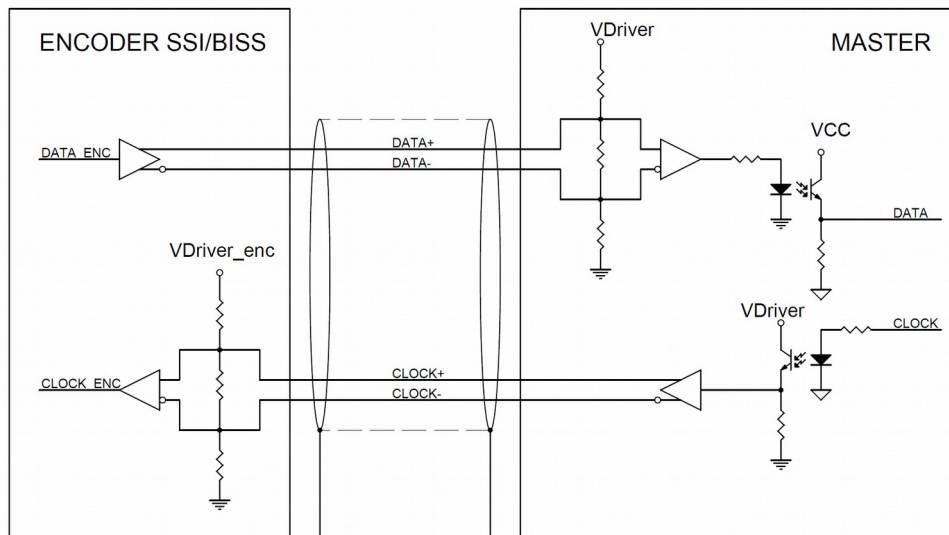

7 - BiSS C-mode interface

Order code: standard SMA1-I7-...

SMA1 is a Slave device and complies with the "BiSS C-mode interface" and the "Standard encoder profile".

For detailed information not listed in this manual please refer to the official BiSS website (www.biss-interface.com).

The device is designed to operate in a point-to-point configuration and has to be installed in a "single Master - single Slave" network.



WARNING

Never connect the sensor in a "single Master - Multi Slave" network.

CLOCK MA and DATA SLO signal levels comply with the "RS-422 EIA standard".

7.1 XML file

The product is supplied with an XML file **idbiss4C69.xml** (see at www.lika.biz > **LINEAR ENCODERS** > **ABSOLUTE MAGNETIC SENSORS** > **SMA1**). Install the XML file in your BiSS Master device.

7.2 Communication

The BiSS C-mode protocol uses two types of data transmission protocols:

- **Single Cycle Data (SCD):** this is the primary data transmission protocol. It is used to transmit the process data from the Slave device to the Master device. See the "7.3 Single Cycle Data" section on page 32.
- **Control Data (CD):** transmission of a single bit following the SCD data. It is used to read data from or write data to the registers of the Slave. See "7.4 Control Data CD" section on page 33.

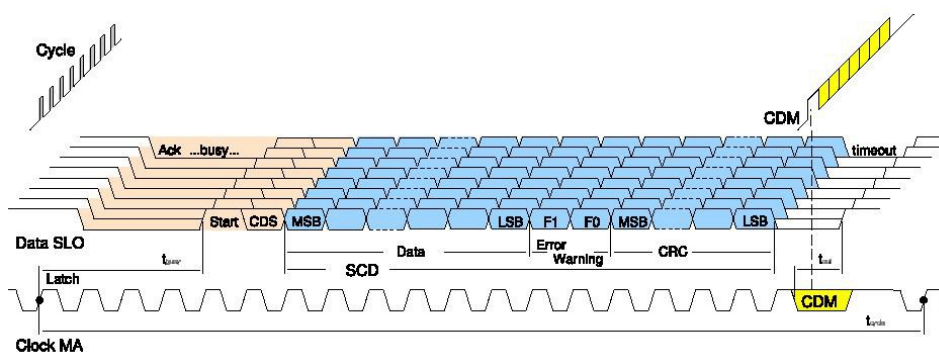

7.3 Single Cycle Data

SCD (32 bits) consists of the following values: 24-bit position value (**Position**), 1 error bit (**Error**, nE), 1 warning bit (**Warning**, nW) and CRC checking (**CRC**, 6 bits).

SCD structure:

bits	31...8	7	6	5...0
function	Position	Error	Warning	CRC

Position

(24 bits)

Process data to be transmitted from the Slave to the Master.

The transmission starts with the MSB (most significant bit) and ends with the LSB (least significant bit).

bit	31 ... 28	27	...	8
value	0000	MSB	...	LSB

To convert the position value into mm, multiply the received data value by the resolution (see 4Dhex **Absolute resolution** register).



EXAMPLE 1

SMA1-SB2-5-..., **Absolute resolution** = 32 hex, 0.05 mm
 detected pulses = 123
 position = 123 * 0.05 = 6.15 mm



EXAMPLE 2

SMA1-SB2-5-..., **Absolute resolution** = 64 hex, 0.1 mm
 detected pulses = 1569
 position = 1569 * 0.1 = 156.9 mm

Error

(1 bit)

It is intended to communicate the normal or fault status of the Slave.

nE = "1": correct status (no active error)

= "0": error status: the scale is not sensed properly.

Check the gap between the sensor and the scale, check both planarity and parallelism. See the "3 - Mounting instructions" section on page 11.

Warning

(1 bit)

Not used (nW = "1")

CRC

(6 bits)

CRC, namely Cyclic Redundancy Check, is the error checking field resulting from a "Redundancy Check" calculation performed on the message contents. This is intended to check whether transmission has been performed properly (inverted output).

Polynomial: X^6+X^1+1 (binary: 1000011)

Logic circuit:

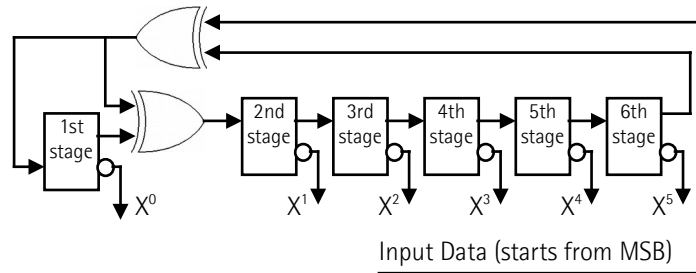

7.4 Control Data CD

For complete CD structure information please refer to the official BiSS documents: "Protocol description C-mode".

Main control data is described in this section.

Register address

(7 bits)

This is the address of the register; it specifies the register you need to read from or write to.

RW

(2 bits)

It sets whether you need to write to the register (**RW** = "01") or to read from the register (**RW** = "10").

RW = "01" : when you need to write to the register

RW = "10" : when you need to read from the register

DATA

(8 bit)

When writing to the register (**RW** = "01"): this is the value to be set in the register (i.e. transmitted from the Master to the Slave).

When reading from the register (**RW** = "10"): this is the value to be read in the register (i.e. transmitted from the Slave to the Master).

Data bit structure:

bit	7	0
	MSB	LSB

CRC

(4 bits)

CRC, namely Cyclic Redundancy Check, is the error checking field resulting from a "Redundancy Check" calculation performed on the message contents. This is intended to check whether transmission has been performed properly (inverted output).

Polynomial: X^4+X^1+1 (binary: 10011)

Logic circuit:

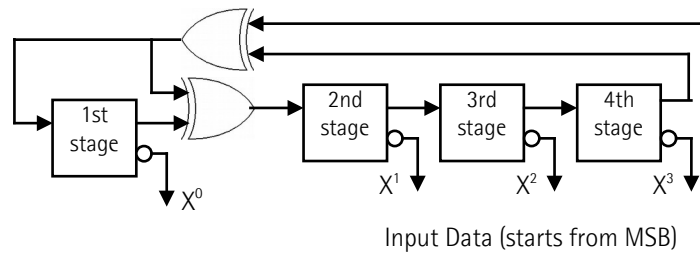

7.5 Used registers

Register (hex)	Function
42 - 43	Profile ID
44 ... 47	Serial number
48	Command
49	Configuration
4D	Absolute resolution
51 ... 53	Preset / Offset
55	Device type
58	SINE / COSINE resolution
78 ... 7D	Device ID
7E - 7F	Manufacturer ID

All registers in this section are listed according to the following scheme:

Function name
[Address, access]
 Description of the function and default value.
 - Address: register address expressed in hexadecimal notation.

- Access: ro = read only
 rw = read and write
 wo = write only
- Default parameter values are written in **bold**.

Profile ID

[42 - 43, ro]

These registers contain the identification code of the used profile.

Register	42	43
Hex	28	14

See "Standard encoder profile", "data format", "Variant 0-24".

Serial number

[44 ... 47, ro]

These registers show the serial number of the device expressed in hexadecimal notation.

- Register 44 : year of production
- Register 45 : week of production
- Registers 46 and 47 : serial number in ascending order

Command

[48, wo]

Value	Function
00	Normal operation
01	Save parameters on EEPROM
02	Save and activate Preset / Offset
04	Load and save default parameters

After having set a new value in some register, use the **Save parameters on EEPROM** function in this register to store it. Set "01" in the register.

After having set a Preset / Offset value, use the **Save and activate Preset / Offset** function in this register to both store and activate the preset / offset at the same time. Set "02" in the register.

Load and save default parameters: default parameters are set at the factory by Lika Electronic engineers to allow the operator to run the device for standard operation in a safe mode. As soon as the command is sent the default parameters are uploaded and activated. All parameters which have been set previously are overwritten, thus previously set values are lost. The complete list of machine data and the relevant default parameters preset by Lika Electronic engineers are available on page 46. Set "04" in the register.



WARNING

As soon as the **Load and save default parameters** command is sent, all parameters which have been set previously are overwritten, thus previously set values are lost!

As soon as the command is sent, the register is set back to "00" (**Normal operation**) automatically.

Wait min. 30 ms (EPROM writing time) before using a new function.

Default = 00 (**Normal operation**)

Configuration

[49, rw]

Bit	Function	bit=0	bit=1
0	Not used		
1	Set preset / offset	Preset	Offset
2	Enable preset / offset	Enable	Disable
3	Not used		
4	Not used		
5	Output code	Gray	Binary
6	Counting direction *	Standard	Inverted
7	Not used		

*: it affects the absolute position information, not the sine/cosine signals

Set preset / offset

This parameter is available only if the **Enable preset / offset** parameter is set to ENABLE. It allows to activate either the preset function (**Set preset / offset** = PRESET) or the offset function (**Set preset / offset** = OFFSET); the Preset or Offset value has to be set in the **Preset / Offset** register. After having enabled the preset / offset functions (**Enable preset / offset** = ENABLE), this item allows to activate either the preset function or the offset function. The value set in the **Preset / Offset** register will have a different meaning depending on the value of this parameter whether it is set to PRESET (0) or OFFSET (1). In the first case (**Set preset / offset** = PRESET) the **Preset / Offset** register is used to set the preset value; while in the second case (**Set preset / offset** = OFFSET) the **Preset / Offset** register is used to set the offset value. To activate the preset / offset value use the **Save and activate Preset / Offset** function in the **Command** register (set "02" in the register 48).

For any information on the preset and offset functions refer to the **Preset / Offset** register on page 38.

Default = 0 (Preset)

Enable preset / offset

It enables / disables the preset / offset functions. After having enabled the use of the functions you have to choose whether to activate the preset or the offset in

the **Set preset / offset** parameter. Then to activate a new value, set it next to the **Preset / Offset** register and send the **Save and activate Preset / Offset** command (set "02" in the register 48).

Default = 0 (enable)

Output code

The sensor provides the absolute position information in the desired code format: GRAY (0) or BINARY (1).

Default = 1 (Binary)

Counting direction

The **standard counting direction** is to be intended with sensor moving as indicated by the arrow in Figure 1. This parameter allows to reverse the counting direction. In other words it allows the count up when the sensor moves in the reverse of the standard direction, i.e. in the opposite direction to the one shown by the arrow in Figure 1. It is possible to choose the following options: STANDARD (0) and INVERTED (1). When the counting direction is set to STANDARD -**Counting direction** = STANDARD-, the position information increases when the sensor moves according to the arrow in Figure 1. When the option INVERTED is set -**Counting direction** = INVERTED-, the position information increases when the sensor moves in reverse of the standard direction, i.e. in the opposite direction to the one shown by the arrow in Figure 1.

Default = 0 (Standard)



NOTE

The **Counting direction** parameter affects the absolute position information, not the sine/cosine signals.

The new setting will be active immediately after transmission. Use the **Save parameters on EEPROM** function (set "01" in the register 48) to store the new value.

Configuration register default value = 20h

Absolute resolution

[4D, rw]

It allows to read and set the resolution of the absolute sensor.

64hex : Resolution = 0.1 mm (max position = 00 FF FFh, 16 bits)

32hex : Resolution = 0.05 mm (max position = 01 FF FFh, 17 bits)

0Ahex : Resolution = 0.01 mm (max position = 07 FF FFh, 19 bits)

05hex : Resolution = 0.005 mm (max position = 0F FF FFh, 20 bits)

The new setting will be active immediately after transmission. Use the **Save parameters on EEPROM** function (set "01" in the register 48) to store the new value.



NOTE

If the preset / offset functions are active, after having set a new value next to this **Absolute resolution** register, then you must check the value in the **Preset / Offset** register and activate it by sending the **Save and activate Preset / Offset** command (set "02" in the register 48).

Default = 05h.

Preset / Offset

[51 ... 53, rw]

This function is available only if the **Enable preset / offset** parameter in the **Configuration** register is set to ENABLE. Furthermore it has a double function depending on whether the **Set preset / offset** parameter in the **Configuration** register is set to PRESET or OFFSET. In the first case (**Set preset / offset** = PRESET) the **Preset / Offset** register is used to set the preset value; while in the second case (**Set preset / offset** = OFFSET) the **Preset / Offset** register is used to set the offset value.



WARNING

Activate the preset / offset value only when the device is not moving.

Preset

The Preset function is meant to assign a value to a desired physical position of the sensor. The chosen physical position will get the value set next to this item and all the previous and following positions will get a value according to it. This function is useful, for example, when the zero position of the sensor and the zero position of the axis need to match. The preset value will be set for the position of the sensor in the moment when the preset value is activated. To activate the preset, stop the sensor in the desired position, enter the desired value next to this **Preset / Offset** register and then send the **Save and activate Preset / Offset** command in the **Command** register (set "02" in the register 48).

Offset

The offset function is meant to assign a value to a desired physical position of the sensor so that the output position information is shifted according to the value next to this **Preset / Offset** register. The number of transmitted values will match the max number of position information as per the set resolution, but the output information will range between the **Preset / Offset** value (minimum value) and the sum of the max. position information as per the set resolution (see the **Absolute resolution** register) + the **Preset / Offset** value (maximum value). The offset value will be set for the position of the sensor in the moment when the offset value is activated. To activate the offset, stop the sensor to the desired position, enter the desired value next to this **Preset /**

Offset register and then send the **Save and activate Preset / Offset** command in the **Command** register (set "02" in the register 48).

Preset / Offset structure:

Reg.	51	52	53
	MSB	...	LSB
	$2^{23} - 2^{16}$	$2^{15} - 2^8$	$2^7 - 2^0$

Use the **Save and activate Preset / Offset** function (set "02" in the register 48) to store and activate the new value.

The max. allowed Preset value depends on the set resolution.

resolution = 0.1 → max preset = 00 FF FFh (16 bits)

resolution = 0.05 → max preset = 01 FF FFh (17 bits)

resolution = 0.01 → max preset = 07 FF FFh (19 bits)

resolution = 0.005 → max preset = 0F FF FFh (20 bits)

The Offset value must be less than or equal to the difference between the overall position information (24 bits, see **Position**) and the max. position information allowed by the set resolution (see the **Absolute resolution** register).

Default = **00h**.

Device type

[55, ro]

This register describes the type of device.

Default = **06h**: linear encoder BiSS + SINE/COSINE signals.

SINE / COSINE resolution

[58, ro]

This register describes the period of the sine/cosine signal.

Default = **01h**: resolution = 1mm

Device ID

[78 ... 7D, ro]

These registers show the Device ID, hexadecimal values are according to ASCII code.

Reg.	78	79	7A	7B	7C	7D
Hex	53	4D	41	31	xx	xx
ASCII	S	M	A	1	-	-

xx: software version

Manufacturer ID

[7E – 7F, ro]

These registers show the Manufacturer ID, hexadecimal values are according to ASCII code.

Reg.	7E	7F
Hex	4C	69
ASCII	L	i

Li = Lika Electronic.

7.6 Application note

Device communication specifications:

Parameter	Value
Clock Frequency	min 200 kHz, max 10 MHz
BiSS Timeout	auto adaptation to clock, max 16 µs
Internal position update frequency	6 kHz

7.7 Examples

All values are expressed in hexadecimal notation, unless otherwise indicated.



7.7.1 Setting the Configuration register

Bit 0	= not used	= 0
Bit 1 Set preset / offset	= PRESET	= 0
Bit 2 Enable preset / offset	= ENABLE	= 0
Bit 3	= not used	= 0
Bit 4	= not used	= 0
Bit 5 Output code	= BINARY	= 1
Bit 8 Counting direction	= INVERTED	= 1
Bit 7	= not used	= 0

01100000₂ = 60 hex

Function	ADR	DATA Tx
writing the Configuration register	49	60
Save parameters on EEPROM	48	01



7.7.2 Setting the Preset / Offset register

After having enabled and chosen the PRESET function (**Enable preset / offset** = ENABLE; **Set preset / offset** = PRESET in the **Configuration** register, see the previous "7.7.1 Setting the Configuration register" section), you want to set and activate the new Preset value = $100000_{10} = 01\ 86\ A0h$

Function	ADR	DATA Tx
writing the Preset / Offset register	51	01
	52	86
	53	A0
Save and activate Preset / Offset	48	02

7.8 Recommended BiSS circuit

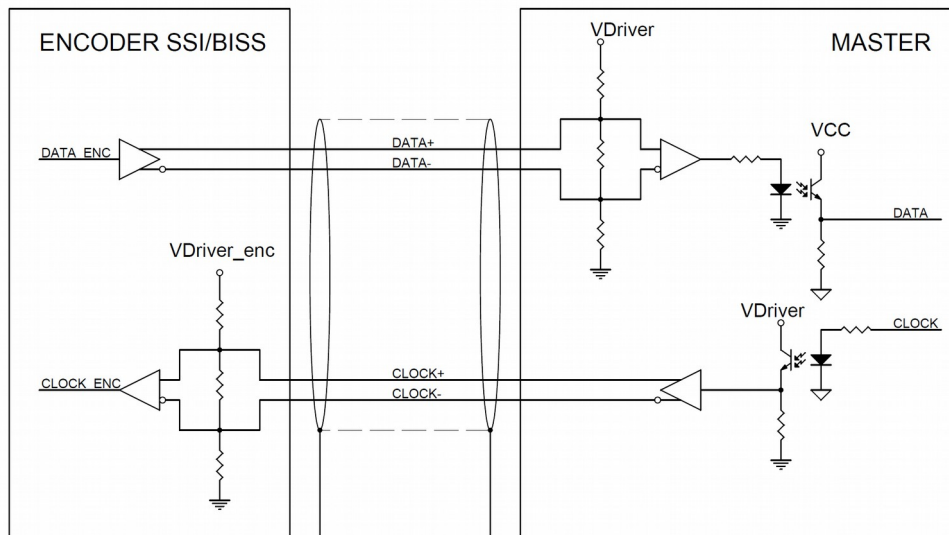

8 - 1Vpp sine/cosine output signals



WARNING

1Vpp sine/cosine output signals are only available for SMA1-SBx-... and SMA1-SCx-... order codes.

The frequency of sine/cosine output signals is proportional to the displacement speed of the sensor.

A (COSINE) and B (SINE) signals (standard counting direction, see Figure 1)

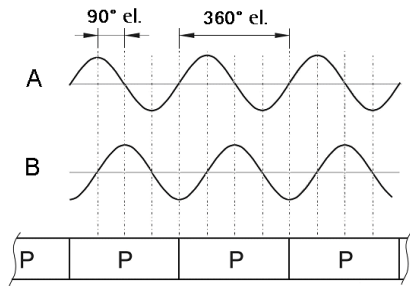

P is the electrical period length.

P = 1 mm, i.e. the resolution.



NOTE

Please note that the **counting direction** function available in the BiSS interface only affects the absolute position information, not the sine/cosine signals.

8.1 Output signals voltage level

The voltage level refers to the differential value between normal and inverted signal (differential).

Recommended input circuit

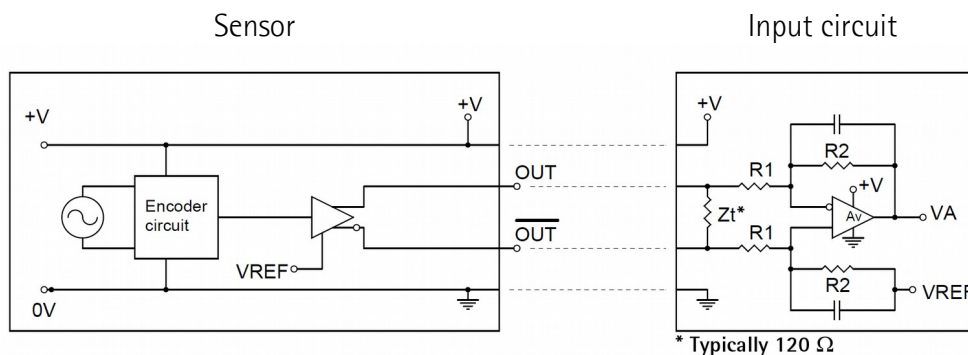

$$V_{REF} = 2.5V \pm 0.5V$$

$$V_A = 1V_{pp} * A_v$$

$$A_v = R2 / R1$$

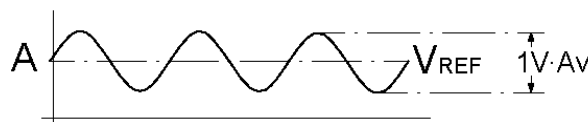

9 - Error and fault diagnostics

In case of wrong alignment between the sensor and the magnetic scale, at power on or during operation the following errors may occur:

- the LED lights up when switching on the system: there is a wrong alignment; it may cause invalid data to be transmitted; please install the sensor properly; as soon as the sensor is aligned correctly the LED switches off;
- the LED lights up during operation: the last valid position is "frozen" (kept in memory) until the next valid position is detected on the scale.

9.1 Diagnostic LED

When the LED lights up, it indicates that an error is active, such as for instance an incorrect alignment between the sensor and the scale:

- the gap between the sensor and the scale is out of tolerance (see Figure 2)
- the sensor is not installed properly
- the sensor or the scale are installed upside down
- the sensor is installed in the opposite direction to the one shown in the Figure 1
- the sensor is travelling too fast
- the power supply is not as required

With BiSS interface, the device status is transmitted via the **nE** bit (see the **Error** bit on pages 22 and 32).



NOTE

When the LED is off, this means that the sensor is working properly and the absolute position is output correctly. Please note that the sine-cosine signals does not affect the LED operation.

For further information refer also to the "11 - Troubleshooting" section on page 45.

10 - Maintenance

The magnetic measurement system does not need any particular maintenance; anyway it has to be handled with the utmost care as any delicate electronic equipment. From time to time we recommend the following operations:

- periodically check the soundness of the structure and make sure that there are no loose screws; tighten them if necessary;
- check the gap between the sensor and the magnetic scale all along the whole measuring length. Wear of the machine may increase the tolerances;
- the surface of the magnetic scale has to be regularly cleaned using a soft and clean cloth to remove dust, chips, moisture etc.

11 - Troubleshooting

The following list shows some typical faults that may occur during installation and operation of the magnetic measurement system.

Fault

The system does not work (no pulse output).

Possible cause

- The scale and/or the sensor are not installed properly (the active surface of the scale does not match the sensitive part of the sensor). For correct installation please refer to the "3 - Mounting instructions" section on page 11. The diagnostic LED is lit.
- A magnetic part or a protection surface is interposed between the sensor and the scale. Only non-magnetic materials are allowed between the sensor and the scale. The diagnostic LED is lit.
- Installation does not comply with the tolerance gap between the sensor and the scale indicated in this guide; the sensor hits the surface of the scale or is too far from it. Check whether the sensor sensitive part is damaged.
- The sensor has been damaged by short circuit or wrong connection.

Fault

The measured values are either inaccurate or not provided in the whole length.

Possible cause

- The gap between the sensor and the scale is not respected all along the whole measuring length (see the "3 - Mounting instructions" section). The diagnostic LED is lit.
- The sensor is not installed properly on the scale (see the "3 - Mounting instructions" section). The diagnostic LED is lit.
- The connection cable runs near high voltage cables or the shield is not connected properly.
- The frequency of the Master clock is set too high or too low and the transmission cannot be synchronized correctly (see the sections "5 - SSI interface", "6 - BiSS B-mode interface" and "7 - BiSS C-mode interface").
- A section of the magnetic scale has been damaged mechanically or magnetically along the measuring length.
- The measuring error is caused by a torsion in the machine structure. Check parallelism and symmetry in the movement of the machine.

For further information refer also to the "9 - Error and fault diagnostics" section on page 43.

12 - Default parameters list

BiSS B-mode interface

Parameters list	Default value *		
Command	00		
Configuration	20		
Bit 0 Select BiSS / SSI	0 = BiSS		
Bit 1 Set preset / offset	0 = Preset		
Bit 2 Enable preset / offset	0 = Enable		
Bit 3 not used	0		
Bit 4 not used	0		
Bit 5 Output code	1 = Binary		
Bit 6 Counting direction	0 = Standard		
Bit 7 not used	0		
Absolute resolution	05		
Preset / Offset	00 00 00		

BiSS C-mode interface

Parameters list	Default value *		
Command	00		
Configuration	20		
Bit 0 not used	0		
Bit 1 Set preset / offset	0 = Preset		
Bit 2 Enable preset / offset	0 = Enable		
Bit 3 not used	0		
Bit 4 not used	0		
Bit 5 Output code	1 = Binary		
Bit 6 Counting direction	0 = Standard		
Bit 7 not used	0		
Absolute resolution	05		
Preset / Offset	00 00 00		

* All values are expressed in hexadecimal notation.

This page intentionally left blank

Document release	Release date	Description	HW	SW	Interface
1.0	13.12.2006	First issue			
1.1	29.04.2008	Added CRC calculations "Operating parameters": default=0			
1.2	05.05.2008	"4 - Electrical connections" Section update			
2.0	16.05.2008	SW update			
2.1	03.10.2008	Added SSI interface "4 - Electrical connections" section update			
2.2	07.11.2008	Note about MCD bit (section "6.4 Sensor mode")			
2.3	12.10.2010	"5 - SSI interface" section update			
2.4	28.08.2013	General amendment, mounting instructions added			
2.5	23.05.2014	Section 6.2 update			
2.6	06.08.2014	"3 - Mounting instructions" section update			
2.7	20.04.2016	General review, new BiSS order codes			
2.8	11.05.2016	M12 12-pin connector added			

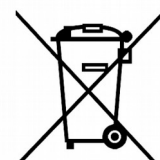

Dispose separately

lika

Lika Electronic

Via S. Lorenzo, 25 • 36010 Carrè (VI) • Italy

Tel. +39 0445 806600

Fax +39 0445 806699



info@lika.biz • www.lika.biz